

GH

Cranes & Components

TRANSFER CARTS and traversers



BATTERY STEERABLE

BATTERY POWERED RAIL-MOUNTED

ELECTRIC POWERED RAIL-MOUNTED

TRANSFER CARTS, BATTERY STEERABLE, BATTERY POWERED RAIL-MOUNTED, ELECTRIC POWERED RAIL-MOUNTED.



GH transfer carts move loads of all types at ground level, for all industries and a huge variety of applications.

These heavy-duty modular transfer carts are available in a wide range of capacities and dimensions to suit any requirement. They are equipped with all the safety devices needed for ground-level machinery movement.

They are an important complement to cranes lifting heavy loads at ground level and the ideal solution for cargo transfer between ships.

There are two main types of transfer carts, according to movement type::

- **Steerable transfer carts:** These move in any direction. Available in battery powered version.
- **Transfer carts on rails:** These move in a straight line. Available in battery-powered or electric versions, with movement via a winder or power line.



BATTERY POWERED STEERABLE TRANSFER CARTS

We manufacture steerable (free-moving) transfer carts ranging from 10 to 60 tons. They are independent, battery powered and can move freely on flat ground, inside and outside the building.



BATTERY POWERED RAIL-MOUNTED TRANSFER CARTS

Rail-mounted transfer carts (straight line travel only) are manufactured in capacities ranging from 10 to 100 tons. They are battery powered and run on rails.



ELECTRIC POWERED RAIL-MOUNTED TRANSFER CARTS

Our rail-mounted transfer carts (straight line travel only) are manufactured in capacities ranging from 10 to 100 tons. They can be powered via a winder or a shielded cable.

INSTALLATION EXAMPLES

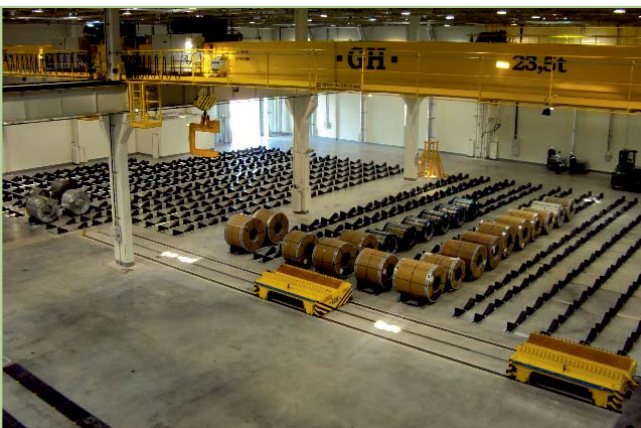
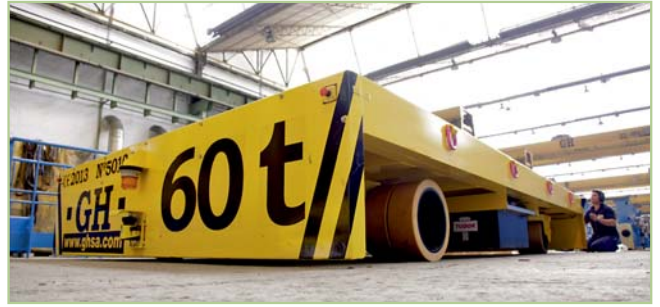

Dimension chart

Load capacity (t)	Dimensions (mm)					Outer wheel radius, minimum rotation (mm)	Speed (m/min)	Battery
	a	b	c	d	e			
20	3000	1600	2000	1500	735	5500	20	48v 400Ah
		2100		2000		6100		
40	4000	2100	2500	2000	775	8900		
	5000	2100	3500			11700		
60	3500	2100	2430	2000	820	6050		
	6000	3500	4000	3200	890	8650		

- Battery charger
- Button panel control with 3 m hose
- Optional: Infra-red control on front and rear.
- Optional: SICK scanner.

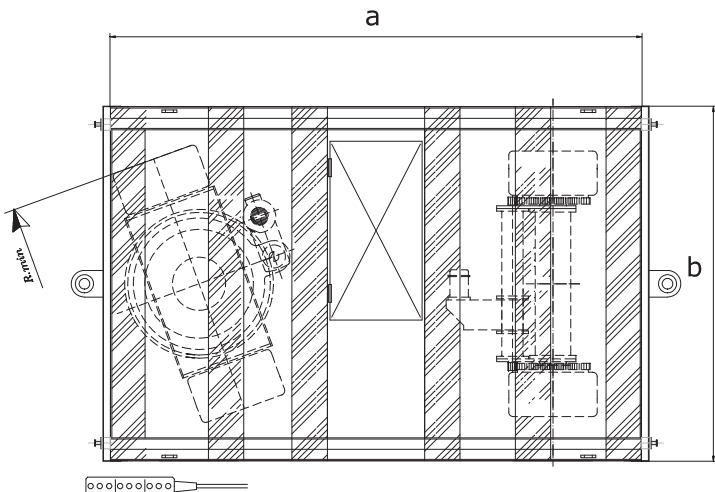
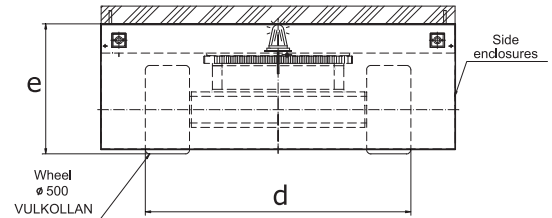
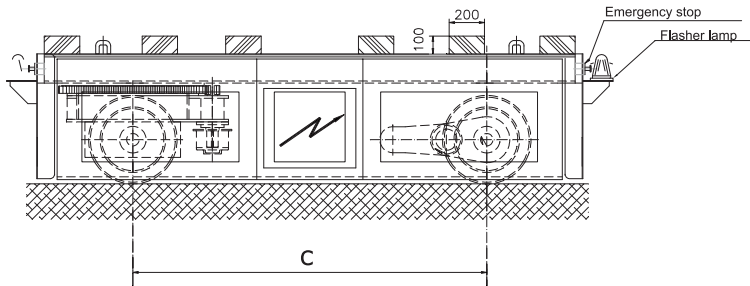

BATTERY POWERED RAIL-MOUNTED TRANSFER CARTS

Dimension chart

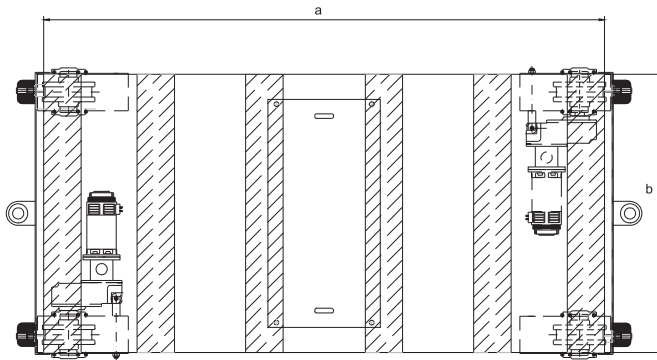
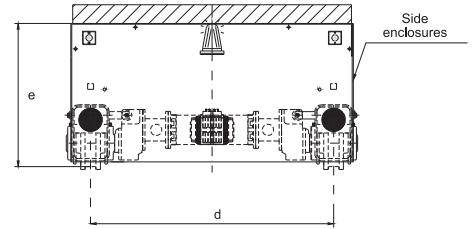
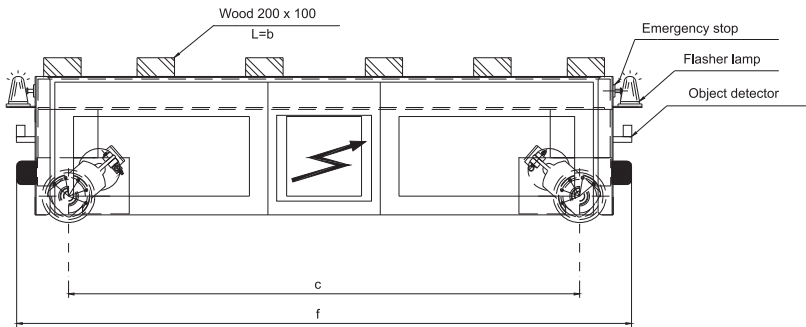

Cap. (t)	Dimensions (mm)						Speed (m/min)	Wheel Ø	Battery
	a	b	c	d	e	f			
10	1500	1000	1234	800	766	2154	20	250	48v 332Ah
	2000	1500	1734	1300		2288			
	3000	2000	2734	1800		3288			
20	2000	1500	1734	1300	766	2288	20	250	48v 332Ah
	3000	2000	2734	1800		3288			
	4000	2500	3734	2300		4288			

- Battery charger
- Button panel control with 3 m hose
- Optional: Radio control
- Optional: Wooden blocks on frame

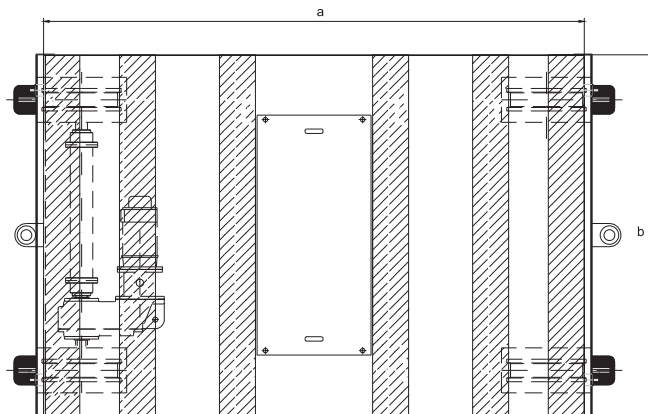

Cap. (t)	Dimensions (mm)						Speed (m/min)	Wheel Ø	Battery
	a	b	c	d	e	f			
40	3000	2000	2680	1800	694	3330	20	315	48v 400Ah
	4000		3680			4330			
	5000	3000	4580	2700		5330			
60	4000	2500	3580	2200	900	4330	20	400	48v 480Ah
	5000	3000	4580	2700		6330			
	6000	3500	5580	3200		6330			
80	6000	3000	5000	2400	965	6430	20	400	48v
100	6000	4000	5000	3100	780	6500	20	630	480Ah

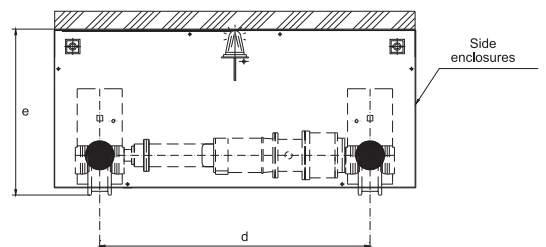
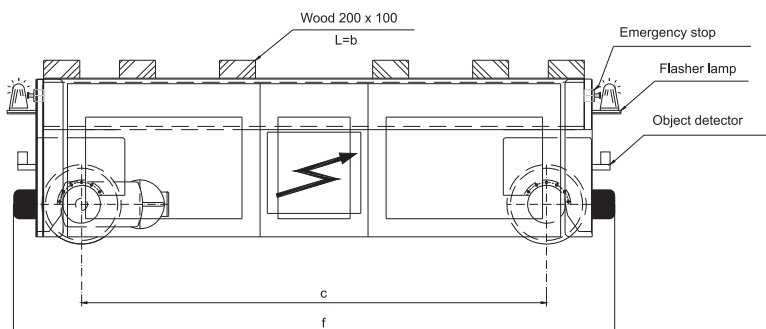

ELECTRIC POWERED RAIL-MOUNTED TRANSFER CARTS

Dimension chart

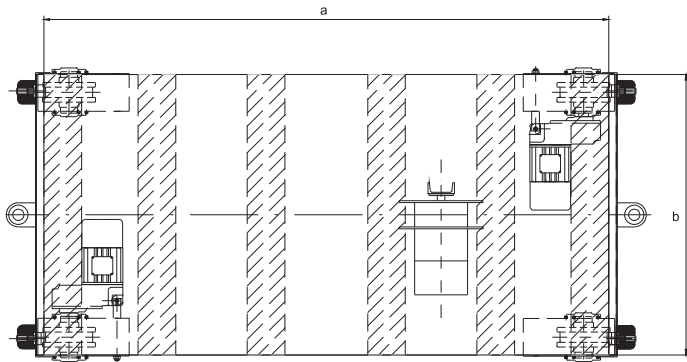
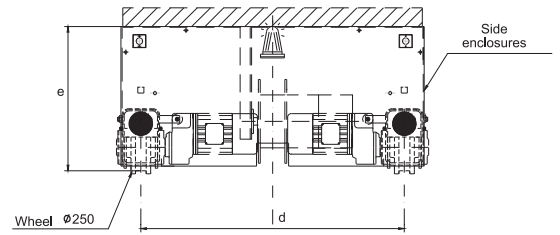
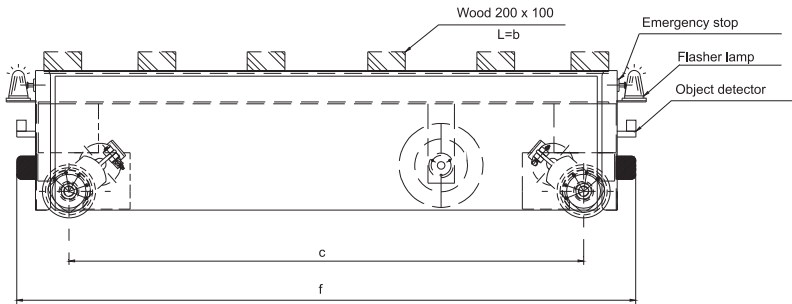

Cap. (t)	Dimensions (mm)						Speed (m/min)	Wheel Ø
	a	b	c	d	e	f		
10	1500	1000	1234	800	766	2154	20	250
	2000	1500	1734	1300		2288		
	3000	2000	2734	1800		3288		
20	2000	1500	1734	1300	766	2288	20	250
	3000	2000	2734	1800		3288		
	4000	2500	3734	2300		4288		

- Spring-powered winder with 20 m travel
- Button panel control with 3 m hose
- Optional: Radio control
- Optional: Wooden blocks on frame

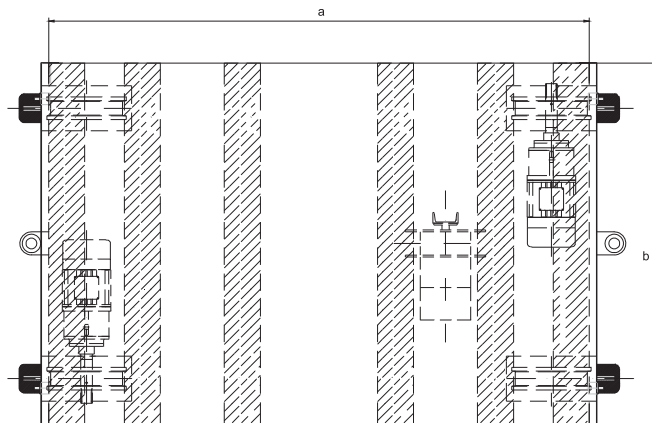

Cap. (t)	Dimensions (mm)						Speed (m/min)	Wheel Ø
	a	b	c	d	e	f		
40	3000	2000	2680	1800	694	3330	20	315
	4000		3680			4330		
	5000		4680			5330		
60	4000	2500	3580	2200	900	4330	20	400
	5000	3000	4580	2700		5330		
	6000	3500	5580	3200		6330		
80	2000	5000	1150	4000	1045	3122	20	400
100	6490	5500	5870	3800	880	6980	20	500

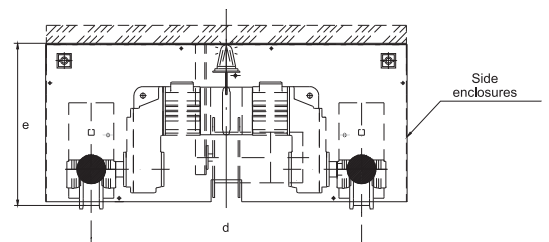
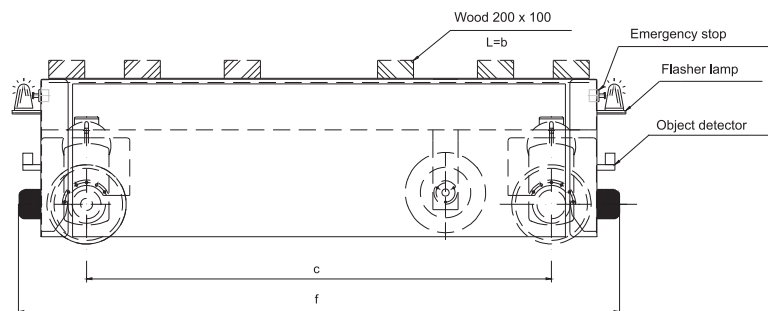

TRANSFER CARTS FOR MOVING RAILWAY VEHICLES



GH also manufactures rail vehicle transfer carts with capacities ranging from 60 to 150 tons, mainly used for moving trains for maintenance work. They are quick, safe and easy to move.





BEASAIN

**CENTRAL OFFICES
TECHNICAL OFFICE**



ALSASUA

**CENTRAL OFFICES
MACHINING WORKSHOP**



BAKAIKOA

**CENTRAL OFFICES
MACHINING WORKSHOP**



BRAZIL

SAO PAULO
GH DO BRASIL IND. E COM. LTDA.
Tlf.: +55 11 4409 0066
www.ghdobrasil.com.br
ghdobrasil@ghdobrasil.com.br



CHINA

SHANGHAI
LIFTING EQUIPMENT CO.,LTD.
Tlf.: +86 6299 7681
www.ghsa.com/ch
ghchina@ghsa.com



FRANCE

COUÉRON
GH FRANCE, SA
Tlf.: +33 (0) 240 86 12 12
www.ghfrance.fr
ghfrance@ghsa.com



MEXICO

QUERETARO
GRÚAS GH MÉXICO SA DE CV
Tlf.: +52 44 22 77 54 37
www.ghsa.com.mx
ghmexico@ghsa.com.mx



POLAND

KŁOBUCK
GH INTERTECH
Tlf.: +48 34 3597317
www.ghsa.pl
intertech@ghsa.pl



INDIA

PUNE
GH CRANES INDIA
Tlf.: +91 020 64730438
www.ghsa.com
ghindia@ghsa.com



PORTUGAL

OPORTO
GH PORTUGAL
Tlf.: +351 229821688
www.ghsa.com.pt
geral@ghsa.com



RUSSIA

MOSCÚ
GH RUSSIA
Tlf.: + 7 (495) 642 63 12
www.ghsa.ru
ghrussia@ghsa.com



THAILAND

SAMUTPRAKARN
LEE MACHINERY-GH THAILAND
Tlf.: +66 (0)8 4660 1365
www.ghsa.com
ghthailand@ghsa.com



USA

ILLINOIS
GH CRANES CORPORATION
Tlf.: (815) 277-5328
www.ghcranes.com
ghcranescorp@ghsa.com

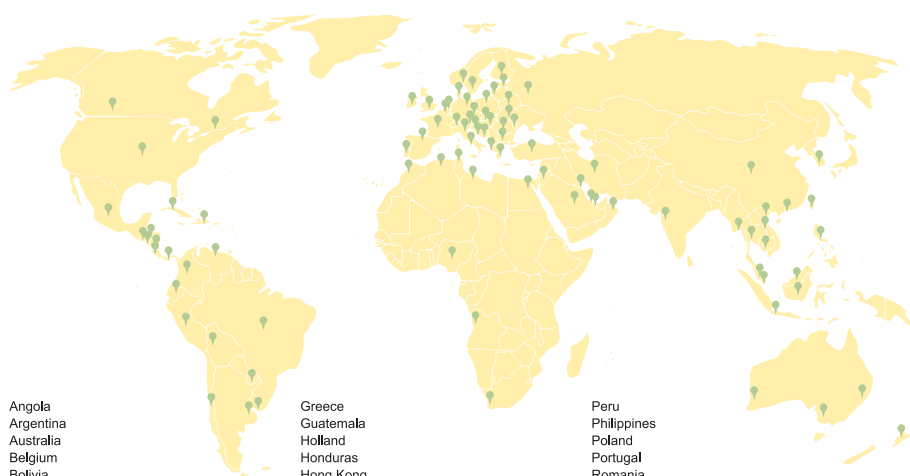

Angola
Argentina
Australia
Belgium
Bolivia
Brazil
Bulgaria
Canada
Chile
China
Colombia
Costa rica
Cuba
Czech Republic
Denmark
Dominican Republic
Ecuador
Egypt
El Salvador
France

Greece
Guatemala
Holland
Honduras
Hong Kong
Hungary
India
Indonesia
Iran
Ireland
Italy
Jordan
Malaysia
Morocco
Mexico
Nicaragua
Nigeria
Norway
New Zealand
Panama
Paraguay

Peru
Philippines
Poland
Portugal
Romania
Russia
Saudi Arabia
Singapore
Slovakia
South Korea
Sweden
Taiwan
Thailand
Tunisia
Turkey
Uk
United Arabemirates
Uruguay
Usa
Venezuela
Vietnam

GH is present in more than 60 different countries, through its local representatives and dealers.

With a staff of over 300 in Spain and 600 worldwide, GH has a weekly production capacity of:

- 50 standard cranes
- 1 special crane
- 40 hoists/kits
- 2 industrial gantries
- 0.5 straddle carriers/travelifts

GH develops both standard and tailored products.

WWW.GHSA.COM



GH
INDUSTRIAS
ELECTROMECHANICAS GH, S.A.

TEL.: +34 943 805 660
FAX: +34 943 888 721
E-MAIL: GHSA@GHSA.COM
APDO. 27 - Bº SALBATORE
20200 BEASAIN
(GIPUZKOA) SPAIN